

PANTER 

ANY WEAVE

ANY WAY



## the rapier loom?

“ The rapier loom?

There were competitors who modified the shuttle, but I didn't believe in that. I looked for a more radical way. I followed a different idea.

When I understood it was technically possible, I didn't give up until I got there. The rapier weaving machines of today prove it was the right path to take. ”

*Nello Pezzoli*



## THE STORY OF UNIQUE KNOW-HOW

The Panter story is one of the rapier insertion system, the technology seen across every textile sector. More than fifty years of uninterrupted know-how development passing from father to son, peerless and driven by a passion to overcome any obstacle, has translated into a story of victory. From this unique passion have come solutions and 'inventions' that, under different names, have established a technology that the textile world has come to appreciate and to this day is the benchmark for versatility, power and quality. Panter is all of this.



## TECHNOLOGY AND ORGANIZATION TO RENEW SOLID KNOW-HOW

It is the ability to look ahead, always ahead, which has allowed Panter to grow and establish itself as one of the most innovative constructors in the textile machinery world. At the heart of this is the attention paid to new technology, new materials and the will to research ever more daring, fresh applications, to overcome the limits of current machines and offer solutions that can open the way to new routes and opportunities.



Only by means of an efficient, solid organization based on strong human values and marked by maximizing resources and potential of the production system, Panter has been able to create an extraordinary entrepreneurial structure which has allowed it to consolidate over the years unsurpassed know-how and make it available to the world of weaving.

## ANY WEAVE, ANY WAY

The real essence of Panter weaving machines is captured in this motto. Every model, each one with its own technological content, carries this distinguishing feature: outstanding flexibility meaning the entire range can cover every production area. MAXI is above all dedicated to the apparel and furnishings sector, HERCULES is specialised in heavy and technical textiles. Finally, UNIRAP, the innovative single rapier for use in non-conventional textile and weave production.



# MUCH MORE THAN WEAVING MACHINES

Panter's extraordinary innovative attitude has resulted in it going outside of conventional ideas for weaving machines and versatility. Today more specifically Panter can offer a modular weaving system based on the combination of various components selected from a platform of mechanical, electronic, and textile solutions, conceived and developed to give an answer to those looking for a machine specifically created for their needs.

Besides the usual option configurations, the customer can choose from different solutions and 'build' the machine that best suits their needs: weft and warp supply (devices) systems, negative or positive rapier insertion systems, different rapier guiding and shed formation solutions can freely be combined.

In both the research into production of innovative textiles and ease and speed of use, this new modular concept has proved a winning one.

## COMMAND AND CONTROL

- ▶ Open Electronic control system offering wide connection possibilities
- ▶ Arrangement for remote control and assistance

## WEFT FEEDING

- ▶ "Dèfiler" conventional system with feeders and motorized weft selector, up to 12 colors
- ▶ Innovative "dèrouler" system in two versions:
  - 2 colors "zero twist" or tape version
- ▶ Hybrid system dèfiler/dèrouler

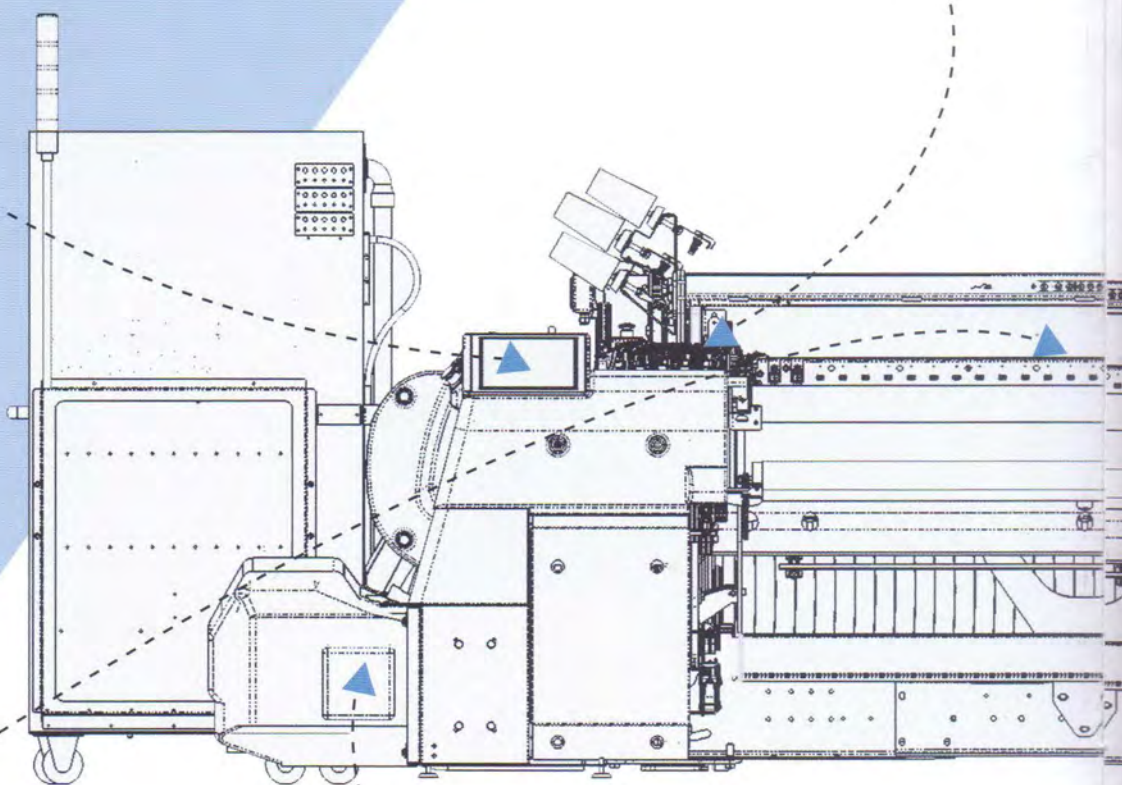

## WEFT INSERTION SYSTEM

- ▶ Bilateral negative or positive rapier system, with central transfer
- ▶ Single positive rapier system, for fancy or special yarns
- ▶ Single positive rapier for tape yarn up to 25 mm

## SHED FORMATION

- ▶ Electronic dobby up to 20 frames
- ▶ Electronic jacquard, any format, with independent or on-frames mounting
- ▶ Independent, motorized drive for dobby or jacquard, type "Armotion"

**Much more than simply personalizing, it is genuinely constructing the ideal machine!**

### **TAPE GUIDE**

- Rapier guiding system with different hook shape and finishing
- HF: hook free rapier raceboard
- RGS: profiled dent reed guiding system

### **WARP FEEDING**

- Warp on beam: single or twin, multiple internal or external versions
- Warp from external creel, with simple or double calender

### **KINEMATICS AND DYNAMICS**

- Original Propeller rapier drive with multi threaded worm screw
- Electronic modulation of the reed stroke system "Reedmotion"

### **FABRIC FORMATION AND TAKE-UP**

- Heavy and dense fabric solution, with adjusting press roller device
- Special additional motorized take-up for super heavy fabrics
- Chromed, anti-creep rotating cylinder version for delicate and low density styles

### **STRUCTURE**

- Self-supporting structure with monocoque elements and multi-layer frames
- Reinforced structure for heavy fabrics and wider width
- Super-structure for jacquard on loom mounting

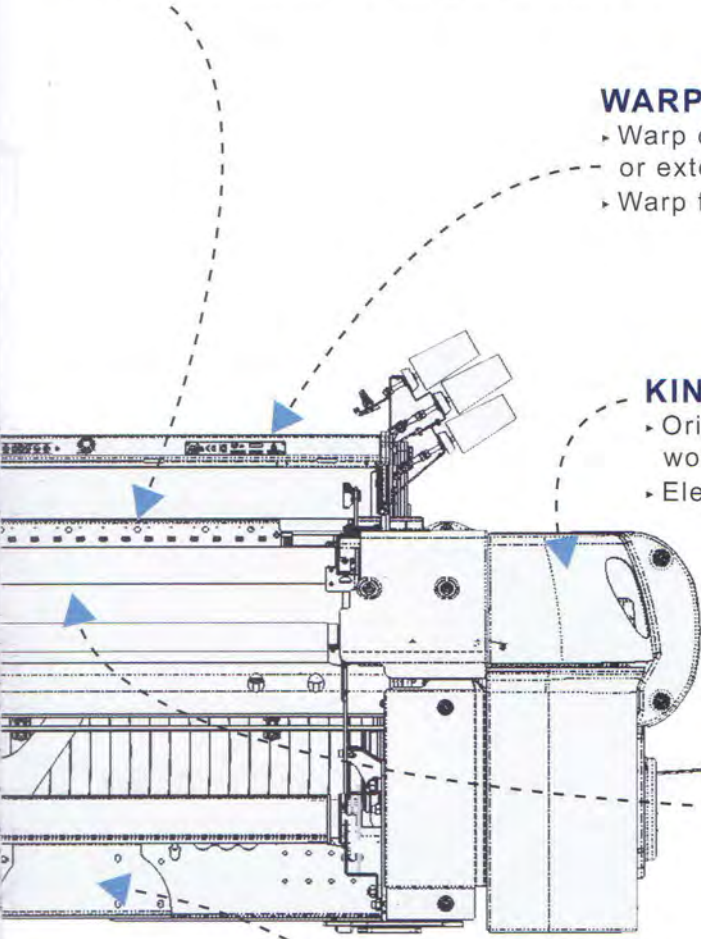

## STRUCTURE

*Self-supporting structure with monocoque elements and multi-layer frames made entirely in ultra-high resistant steels with high damping capacity. No need to fix to the floor.*

*Reinforced version for production of extremely heavy, dense textiles and for very wide machines, up to 5,500 mm, with a higher lay-out to increase the machine's adjustment range.*

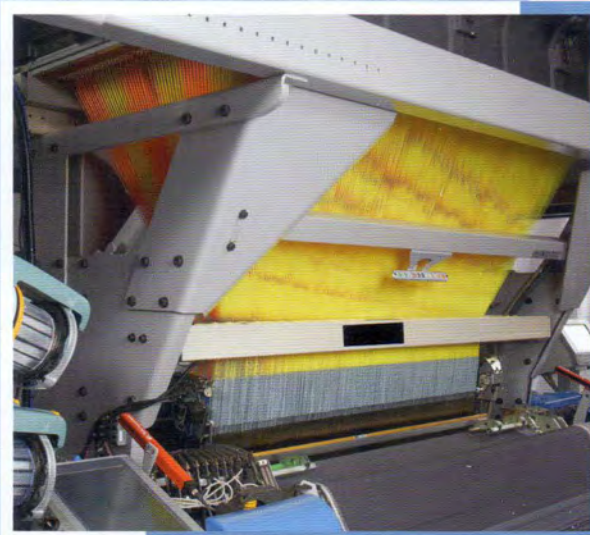
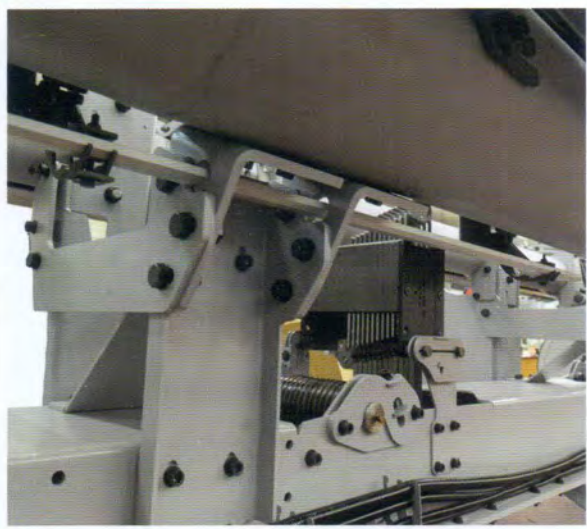

*Super structure to mount the Jacquard machine directly onto the loom: minimum dimensions, maximum handling, reduced set-up times and lower plant costs.*

## MACHINE KINEMATICS AND DYNAMICS

*PROPELLER: the rapier movement mechanism's characteristics optimise acceleration in the crucial points of gripping, exchange and weft release. Available in the standard version for looms up to 3800 mm and in a version with an innovative, multi threaded worm screw for wider widths and special versions.*

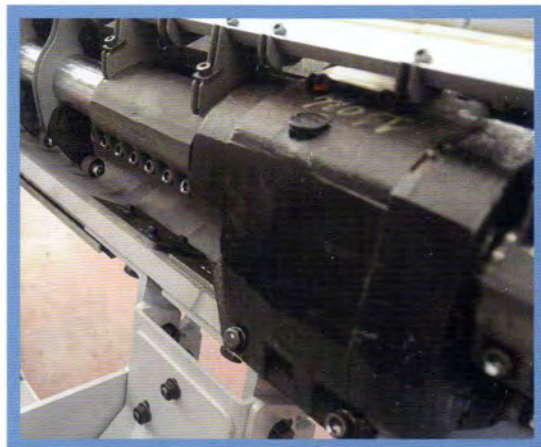
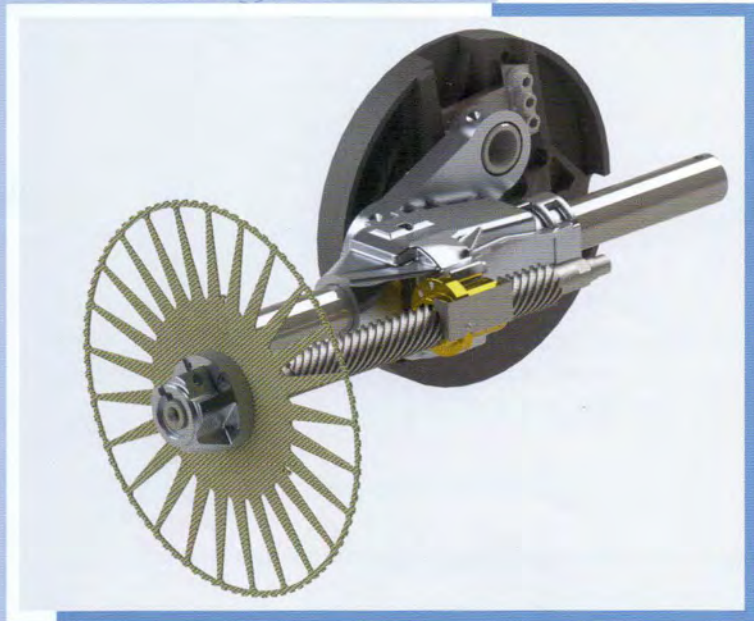

*Along with the classic sley movement with cams, now there is also the REEDMOTION device, which allows electronic modulation of the reed stroke, an essential element for production of non-conventional textiles.*

## WEFT FEEDING

The classic 'dèfiler' system, with motorised weft feeder and weft selector, up to 12 colours: the 'base' solution for traditional weaving.

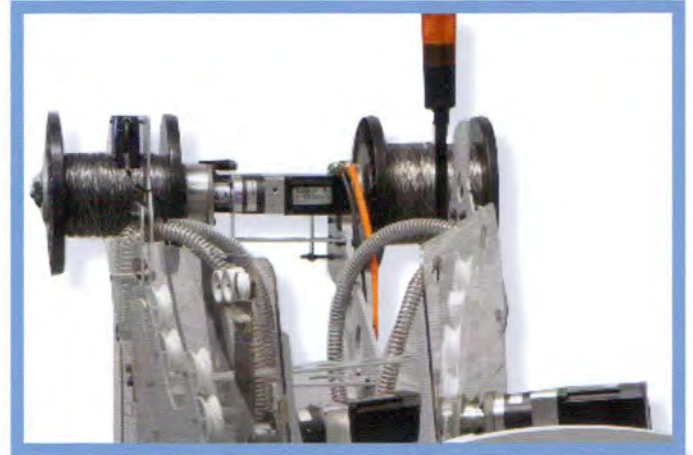
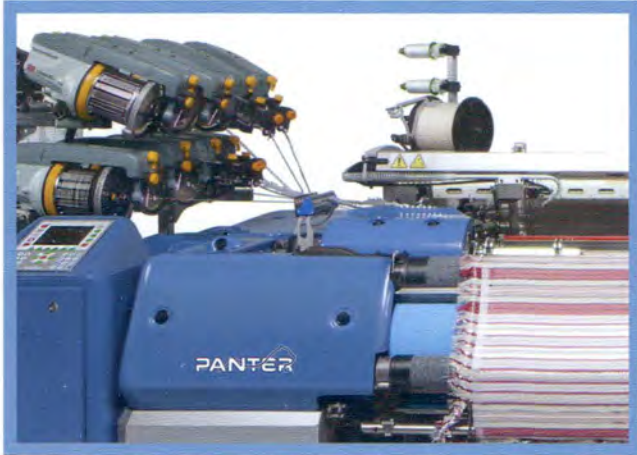

The innovative 'dèrouler' device, with bobbin controlled rotation and a system to compensate for the weft unwinding. Available in the two-colour 'Zero Twist' system or the one for flat yarn up to 25 mm, allowing, for the first time, industrial production of innovative textiles and various weaving.

The 'dèfiler/dèrouler' hybrid system is also available, opening up fresh scenarios in high fashion textiles.

## WARP FEEDING

Beam feeding envisions a variety of versions: single, twin, double and triple, internal and external, upper or lower to maximize productivity and solution possibilities.

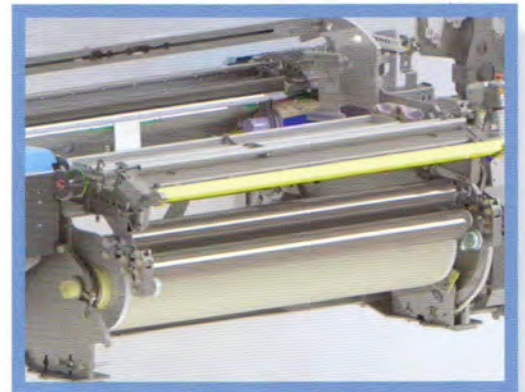
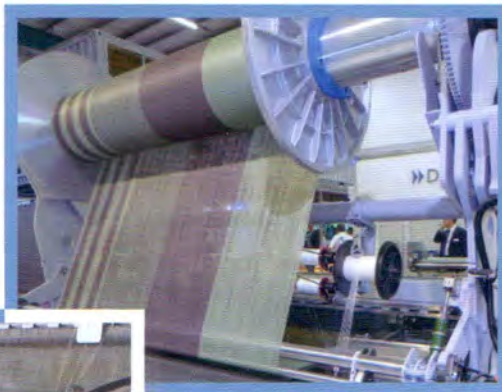

External creel feed, often indispensable in technical textile production, is available to replace or in combination with the beam. The electronically controlled calender (also in double version) ensures a constant and totally reliable warp tension under any conditions.

For optimum warp tension running, the backrest roller is made up of a very rigid load-bearing structure with a very low inertia feeler cylinder (with load cell tension reader) for absolute sensitivity. An increased compensation version for particularly stiff yarns is available as well as one with rotating cylinders and satin finish.

# INSERTION SYSTEM

Thanks to the characteristics of the rapier drive's mechanism, Panter is the only manufacturer on the market offering a negative or positive rapier insertion system. This makes for optimal performance and versatility adapting to the diverse weaving needs.

The single positive rapier version, one of a kind, has been created to guarantee insertion of any kind of weft in the technical and high fashion sectors. Virtually without limits, this rapier is able to work a much more extensive range of yarns. Eliminating the exchange in the centre makes it possible to reduce the weft tension, guaranteeing very high efficiency.

For the more extreme technical sectors, a version with single rapier for flat yarns and tape up to 25 mm wide is available.

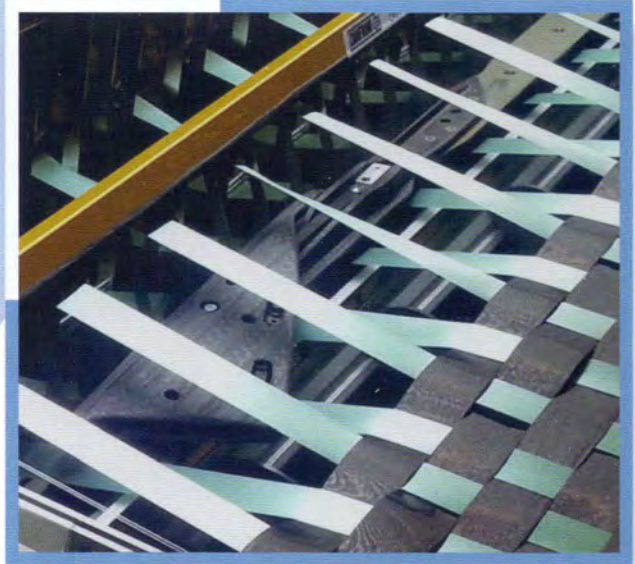
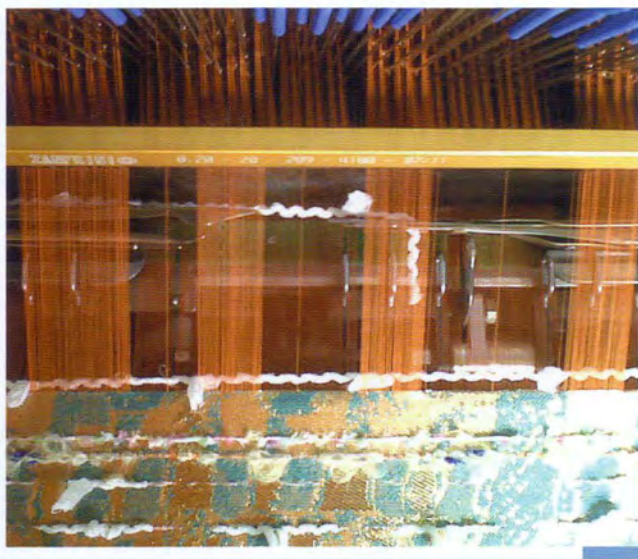

## TAPE GUIDE

The strong point of Panter's know-how, the traditional rapier guiding hook system, adapted efficiently to any type of yarn and style thanks to the hook's manifold finish and form types. A guarantee for production efficiency and quality of the textile produced.

For high-density warp and particularly delicate yarns, there is the HF solution with unguided tape available, easy and quick to manage, with an innovative rapier position in the shed, giving great stability to the tape run.

The Reed Guide System, with a reed made up of profiled dents, is decidedly innovative. A new concept for weaving machines, developed principally for those manufacturing sectors where it is indispensable to guarantee a complete absence of contact between warp and tapes.

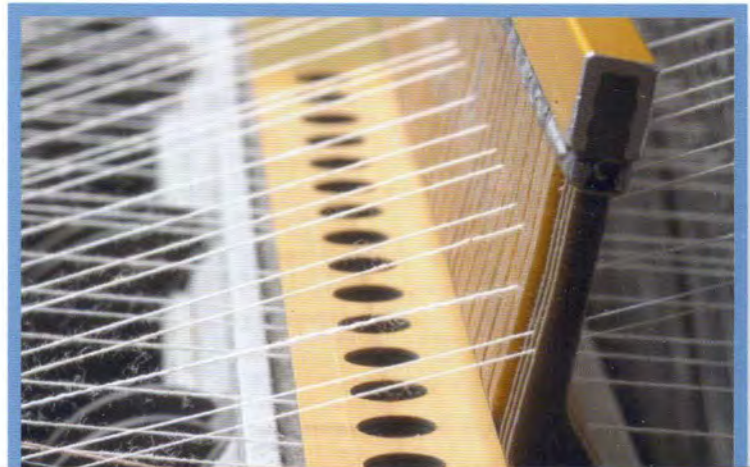
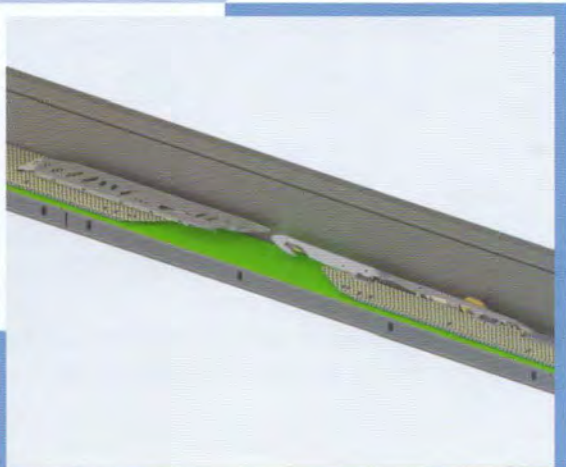



## SHED FORMATION

*In the electronic dobby version of up to 20 frames, various solutions are available for frame coupling; in particular the fast connection DRC4 is recommended for the quick change QSC.*

*Electronic Jacquards, also in formats of over 20,000 hooks, are an ideal combination for producing high fashion and furnishing textiles.*

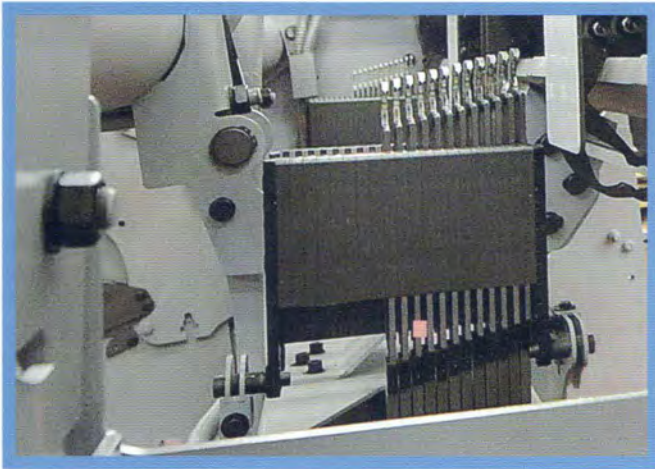

*Mechanical drive of the shedding motion is by belt drive or bevel gearbox or through the innovative motorised, electronically synchronised, ARMOTION system. Available for both dobby and jacquard, it allows independent formation of weft shed and insertion, making it possible to overcome the limits of traditional weaving.*



## FABRIC FORMATION AND TAKE-UP

*To maximize insertion capacity, take up is combined with a press roller using elastic elements to increase the strain and ensure a high, constant holding strength.*

*For particularly heavy fabrics, a version with a cylinder with auxiliary motor is available, guaranteeing no slippage.*

*For net and grids or delicate textiles with a low weft density, where weft movement must be avoided, a chromed, anti-creep rotating cylinder version has been created.*

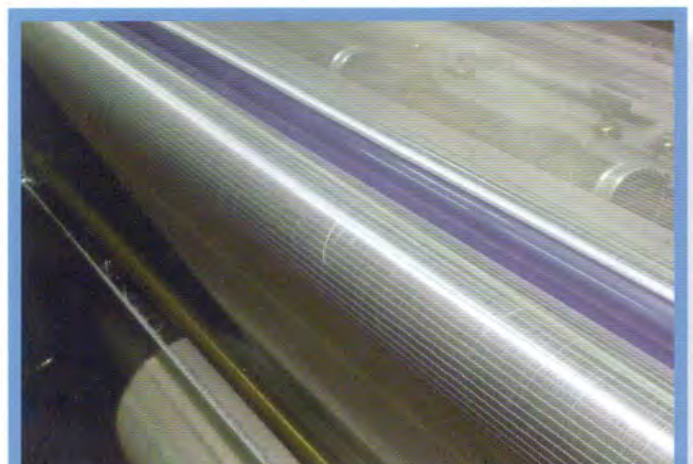
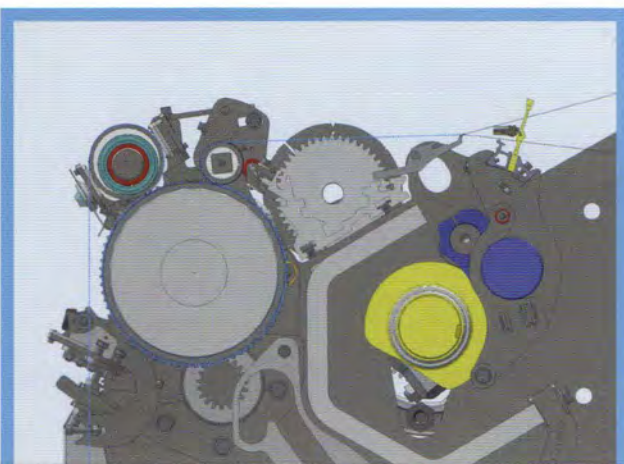

# COMMAND AND CONTROL



*The demand for ever greater performance and flexibility and machines open to different configurations to satisfy diverse manufacturing needs, calls for a powerful and reliable electronic control and command system.*

*The basic version exploits a powerful control unit with double processor to drive the multi-axis machine architecture and manage all the different motorised devices.*

*The system's great potential makes it possible to exploit new brushless motor technologies for the command and control of devices on the machine, such as: cutters, leno devices, weft selectors, opening devices, motorized bobbin unwinding systems, electronic weft brakes.*

*Today machine's evolution is mainly based on the exploitation of the automation.*

*Panter entrusted an extremely high quality supplier, B&R, to design with them an innovative, highly powerful system, able to meet any future need.*

*Available as an option for MAXI and HERCULES, the new electronic platform ensures superior performances and absolute reliability, essential requirements for the innovative UNIRAP.*



*A complete and intuitive interface, able to manage all the machine functions with a simple touch, guaranteeing the greatest range of connections, exploiting the benefits of modern ICT systems.*

*Optimisation of the power in use makes it possible to control energy consumption, while the energy recovery system ensures regeneration with all the running cost and environmental advantages.*



